

CAD FILE:

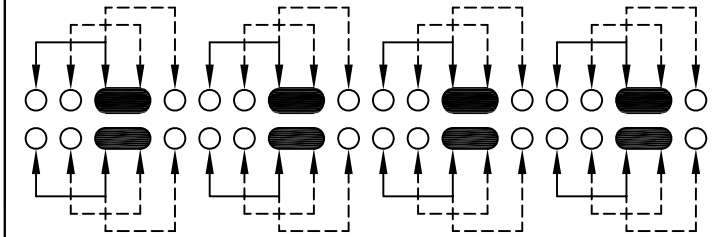

SCHEMATIC (SHORTING)

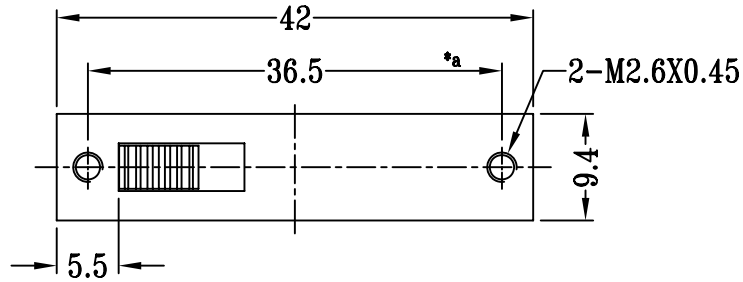
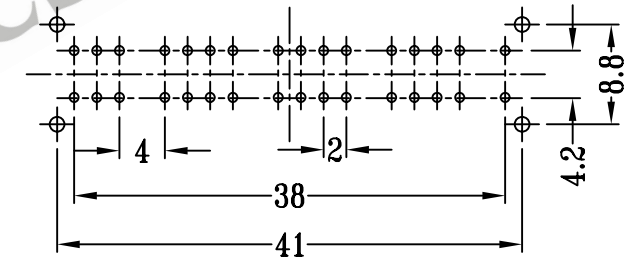
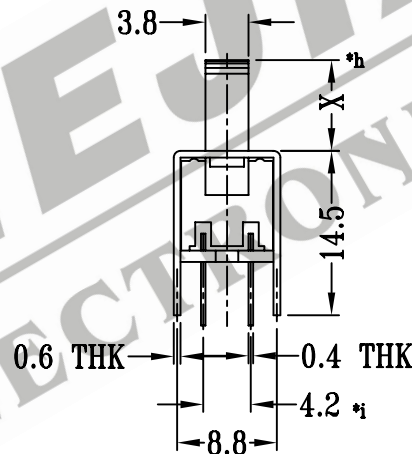
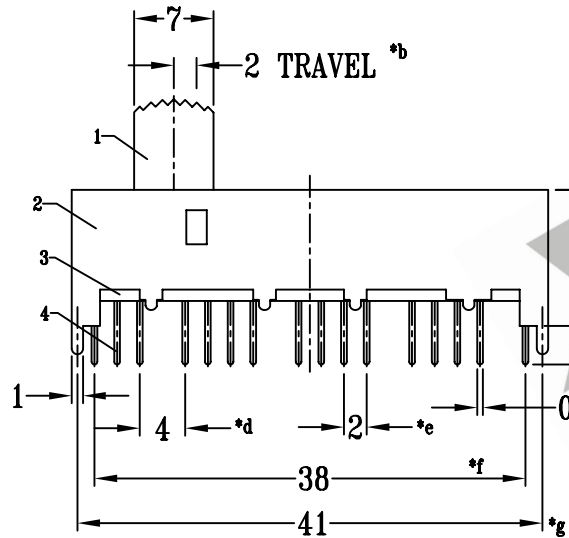

P.C.B LAYOUT

注:带"*"表示关键尺寸(9个)

NO.	PARTS	MATERIALS	QTY	FINISH	TOLERANCE UNLESS SPECIFIED	SHENZHEN XIEJIA ELECTRONICS CO.,LTD.				
8						TITLE: VERTICAL SLIDE SWITCH MODEL: SS-83D01				
7	CONTACT CLIP	PBS STRIP	8	Ag PLATED						
6	STEEL BALL	STEEL	2	NATURAL	WITHIN : 1.5±0.1mm OVER : 1.5±0.2mm	ISSUE	DATE	DESCRIPTIONS OF REVISION		APPD
5	SPRING	STEEL WIRE	1	TEMPER		UNIT : mm		DRWG NO.: XJ-DR-SS83D01-00		
4	TERMINAL	BRASS STRIP	32	Ag PLATED OVER Ni PLATED		SCALE: 3:2		DWN	ZHOUYU	2001-6-21
3	BASE	PHENOLIC RESIN	1	NATURAL				CHK'D	FANGYING	2001-6-21
2	FRAME	STEEL STRIP	1	Ni PLATED				APPD	KANGXINAN	2001-6-21
1	KNOB	POM	1	BLACK				ALL MATERIALS MUST BE COMPLIANT TO ROHS		